

AUTOMATIC FILLING UNIT



Art. 2100

Chrome-plated automatic filling unit without pressure gauge for closed circuit systems. Complete with nonreturn valve, stop cock and strainer.



Art. 2110

Chrome-plated automatic filling unit with pressure gauge for closed circuit systems. Complete with nonreturn valve, stop cock and strainer.

1. DESCRIPTION

Installation of an automatic filling unit is recommended for heating and air-conditioning systems. Such a device is able to automatically fill the system up to the pre-set pressure and is useful in compensating for any pressure decreases resulting from the discharge of air from the circuit via the air vent valves.

Filling units can be used:

- to set the pressure based on the system requirements
- to stop the filling of the system once the pre-set pressure is reached
- to block any eventual backflow, resulting from a pressure decrease within the water supply line once the filling of the system is completed.

Each filling unit comprises:

- Pressure reducing valve
- Non-return valve
- Stop cock
- Strainer
- Pressure gauge for reading system pressure

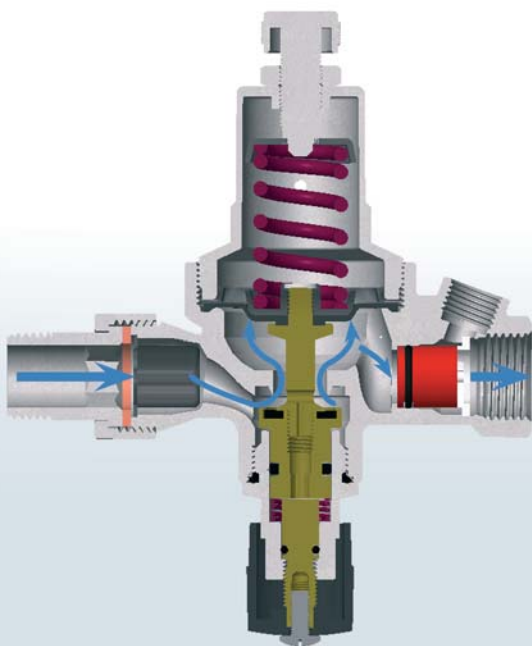

Pressure reduction is achieved by means of a membrane, which is in direct contact with the flow. The membrane itself is spring-loaded with the spring governing movement of the stem and shutter. The desired value of the downstream pressure is set by adjusting a screw located in the upper section of the filling unit, which acts directly on the spring. While the fluid compression on the membrane downstream of the pressure reducer is equal to the force of the spring, the shutter remains closed. Reducing compression the spring overcomes the force of fluid on the membrane and the shutter opens. The flow rate through the filling unit is proportional to the difference between the upstream and downstream pressures on either side of the unit.

2. CONSTRUCTION FEATURES

The pressure reducing device comprises a spring adjustable by means of the calibration screw; a membrane which responds to the water pressure of circuit and a shutter controlling the fluid inlet into the circuit.

Calibration of the filling unit is achieved by adjusting the screw in the upper section. To raise the pressure the screw must be turned in a clockwise direction. Turning the screw counter-clockwise will decrease the pressure. The pressure is adjustable from 0,5 up to 4 bar.

The pressure gauge is required for reading downstream pressure, i.e. the pressure of the supply circuit.

To achieve optimum performance from the filling unit and its associated components it is essential to keep the water free of impurities. Such impurities could damage membranes, or gaskets with prejudice to the sealing and operating efficiency of components.

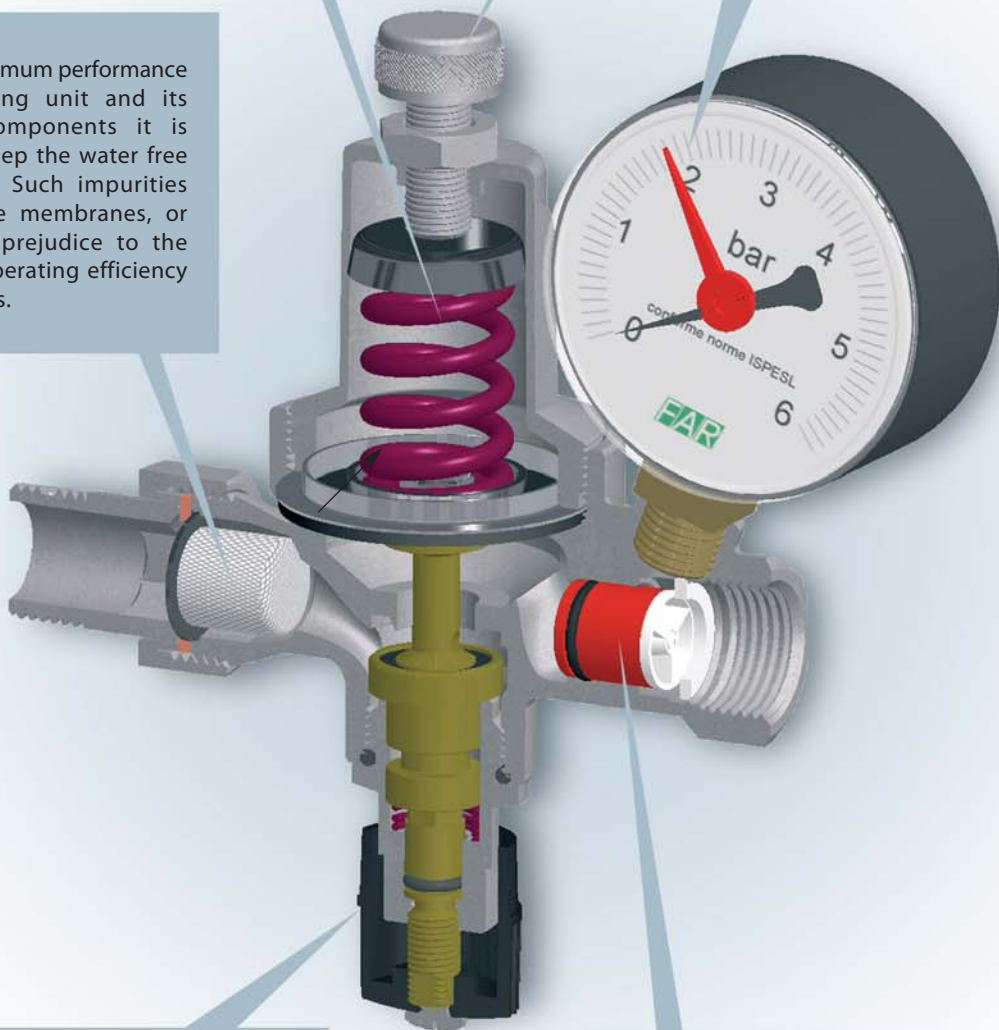

Once the system has been filled it is possible to isolate the water supply line from the heating system by closing the stop cock. The water flow can thus be shut off in the event of any malfunction within the system. This is done usually by qualified staff as it should be regular re-opened in order to allow reinstatement.

The role of the non-return valve is crucial. It is this device which prevents backflow into the water supply line. Such a situation might arise in the event of a pressure rise within the closed circuit due to an increase in temperature, or a pressure reduction within the water supply line.

3. INSTALLATION

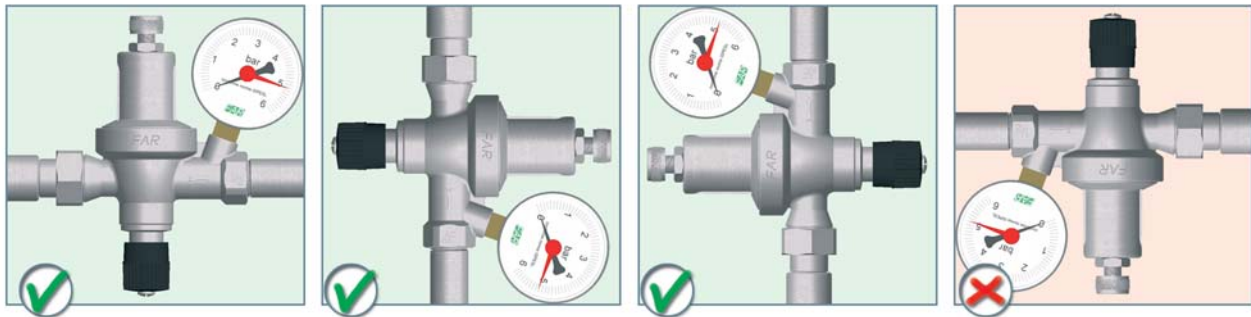
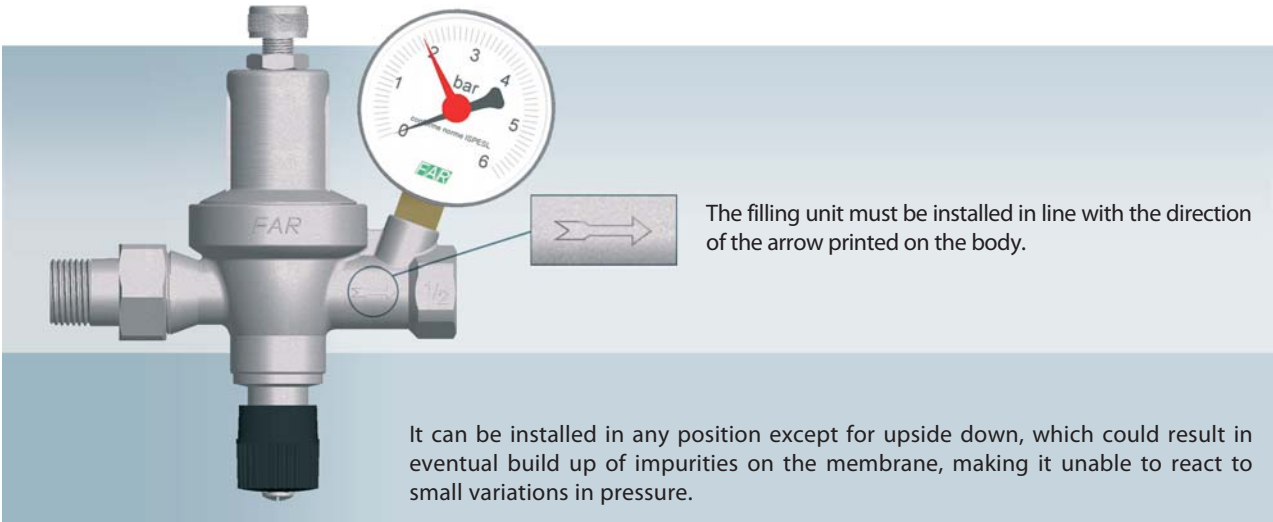

The filling unit is normally installed on the feed line between two shut off valves, so that it can be removed without draining the whole system. During installation the regulating screw must be totally unscrewed and the valves A and B closed. When valve A is opened the upstream pressure of the filling unit is the same as the water network pressure or as the outgoing pressure of the pressure reducing valve located after the meter, and downstream of the filling unit the pressure will be zero. Then turn the calibration screw, screwing it 'till the pressure gauge on the unit shows the desired filling pressure. Now lock the screw with the matching nut, in order to avoid any irregularity due to vibration or tampering. By opening valve B system filling can be

effected in order to achieve the pre-set pressure. It is advisable to install the filling unit with a bypass, in order to reduce filling time. For example: it is possible to fill 2/3 of system with the bypass and the rest with the unit, so as to make easy the eventual bleeding of some air from the system. After the first filling it is recommended that the strainer be cleaned. In order to do this it is essential to: close the shut-off valve on the general feed, close the unit stop cock and unscrew the nut and union. Now remove the strainer and clean it under running water. For easier handling it is advisable to install a 3-piece joint downstream of the filling unit, so as to be able to take it off by simply unscrewing two nuts.

By-pass installation overview



Filling unit with shut-off valves

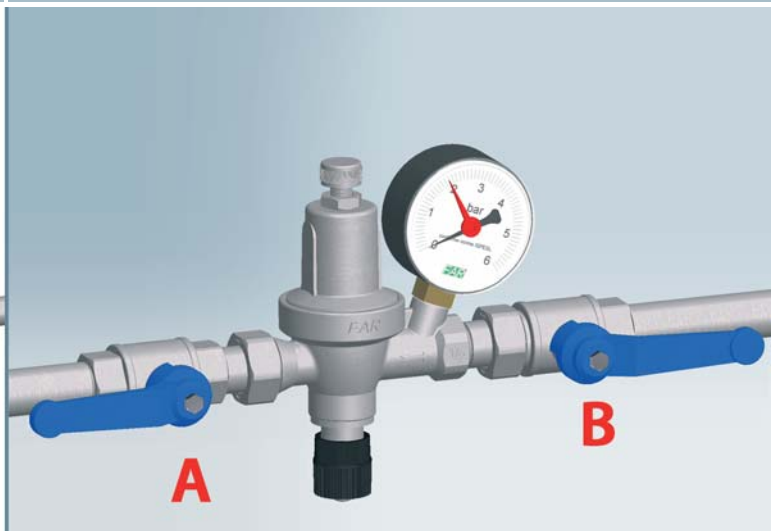

4. INSTALLATION EXAMPLE

The picture shows a typical installation of filling unit at the inlet of the heating system. Usually it is installed on the return circuit just after the pressure reducing valve which supplied the hydraulic system. As has already been made clear, it is important to have a by-pass on the unit in such a way to fill more quickly the system and then to set it on the desired calibration value using the filling unit.

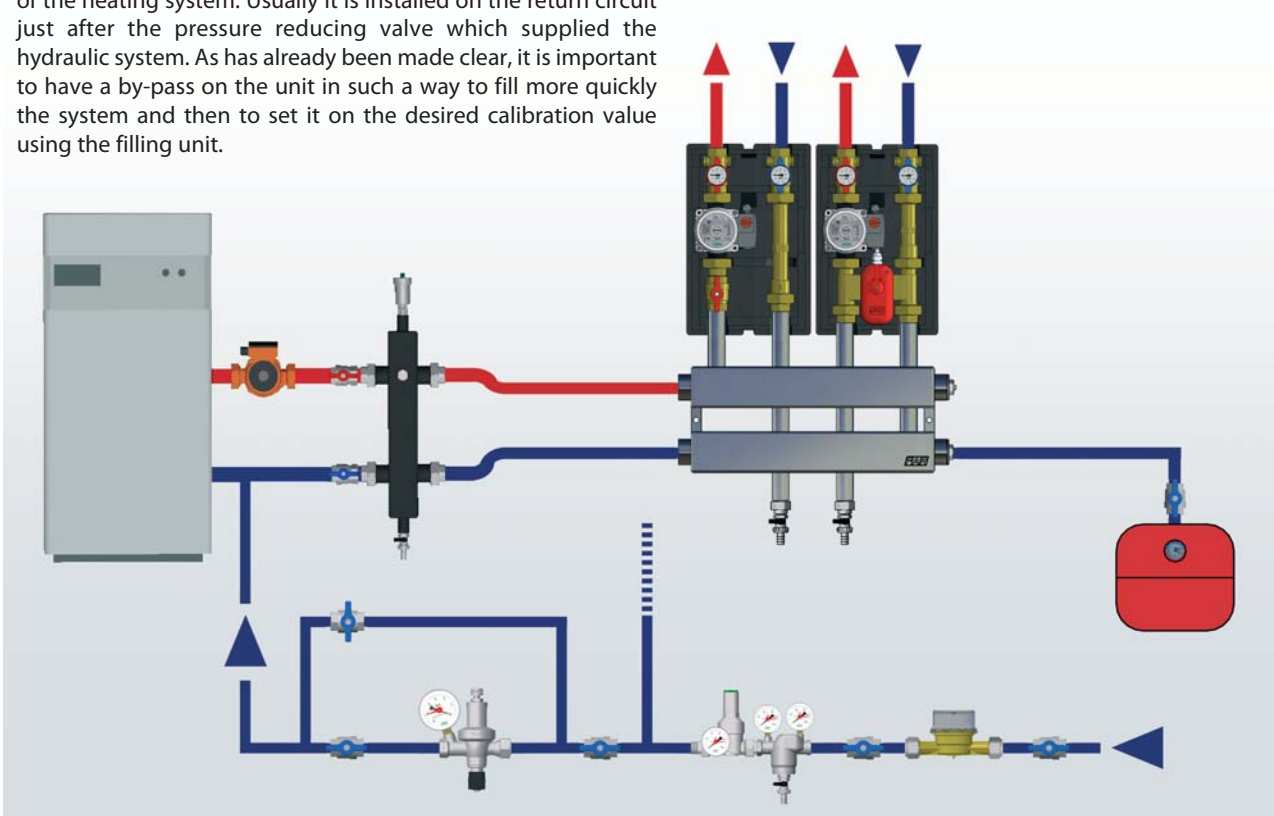

5. DIMENSIONAL FEATURES

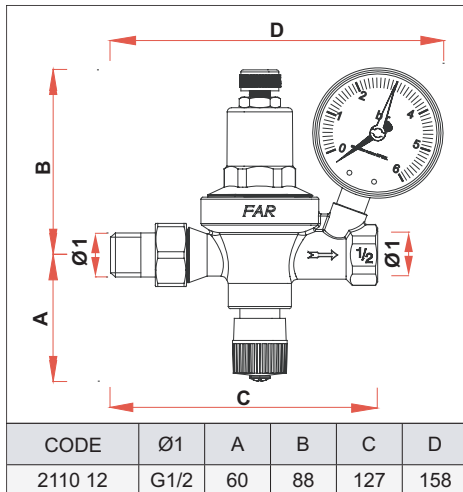

6. TECHNICAL FEATURES

Inlet connection (union):	Ø1/2" M
Outlet connection:	Ø1/2" F
Pressure gauge:	Ø1/4" F
Max. working temperature:	95°C
Min. working temperature:	5°C
Max. upstream pressure:	10 bar
Calibration pressure:	0,5 ÷ 4 bar
Valve body, stem, shutter and inner components:	CW617N and CB753S brass
Spring:	AISI302 steel
Membrane of pressure reducing valve:	NBR
Non-return valve:	differential pressure 0,02 bar
OR gasket:	EPDM
Strainer:	450 µm
Stop cock handle:	ABS